

Technical sheet

EP 16

Warehousing Equipment



	Technical characteristics	Metric
1.1	Manufacturer	Manitou
1.2	Model	EP 16
1.3	Type of traction	Electric
1.4	Type of operation	Stand Up
1.5	Q - Rated capacity	1600 kg
1.6	c - Center of gravity of load	600 mm
1.8	x - Distance from the load bearing surface to the centre of the front axle	964 mm
1.9	y - Wheelbase	1309 mm
Weight		
2.1	Weight of truck in working order	410 kg
2.2	Laden weight on front/rear axle	825 kg / 1185 kg
2.3	Unladen weight on front/rear axle	286 kg / 124 kg
Wheels		
3.1	Tyre equipment: bandage (V), PPS (SE), inflatable tyre (L)	mft_Polyurethane
3.2	Size of front wheels	Ø230 x 70 mm
3.3	Size of rear wheels	Ø0,082 x 0,082
3.4	Size of caster wheels	(Ø100 x 40 mm)
3.5	Number of front wheels (x)	3 / 4
3.6	b10 - Front track	435 mm
3.7	b11 - Rear track	366 mm
Dimensions		
4.2	h1 - Height (mast lowered)	1319.78 mm
4.15	h13 - Height of forks in down position	85 mm
4.19	l1 - Total length	1659 mm
4.20	l2 - Length to fork heel	509 mm
4.21	b1 - Overall width - Single/twin wheels	680 mm / -
4.22	e / s / l - Fork dimensions	1150 x 160 x 47
4.33	Ast - Aisle width for 1000 x 1200 pallet widthwise	1921 mm
4.35	Wa - Turning radius	1475 mm
4.36	b13 - Inner turning radius	1422 mm
Performances		
5.1	Speed of travel laden / unladen	5.80 km/h / 6 km/h
5.2	Lifting speed laden / unladen	0.03 m/s / 0.04 m/s
5.3	Lowering speed laden / unladen	0.05 m/s / 0.05 m/s
5.7	Maximum ramp laden / unladen	10 % / 25 %
5.10	Service brake	Electromagnetic
Engine		
6.3	Size of battery tray as per DIN 43531/35/36, A, B, C, no	BS
6.4	Battery voltage/capacity	24 V / 170 Ah
7.2	Useful power	1 kW
Miscellaneous		
8.4	Measured/guaranteed mean noise level at the ear of the operator	65 dB(A)

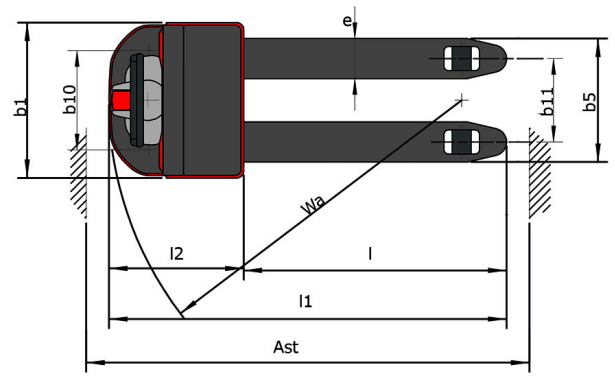
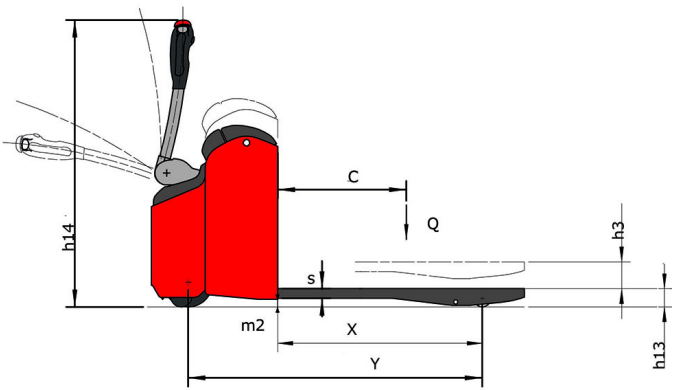

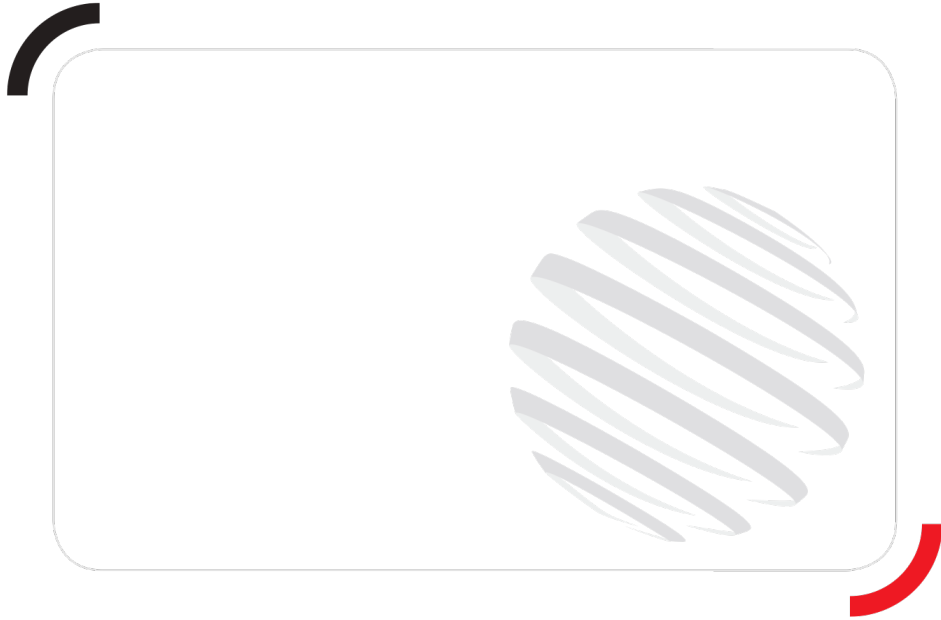

Siège Social
430 rue de l'Aubinière - 44150 Ancenis Cedex - France
Tel: +33(0)2 40 09 10 11 - Fax: +33 (0)2 40 09 10 97
www.manitou.com



This brochure describes versions and configuration options for Manitou products which may be fitted with different equipment. The equipment described in this brochure may be standard, optional or not available depending on version. Manitou reserves the right to change the specifications shown and described at any time and without prior warning. The manufacturer is not liable for the specifications given. For more information, contact your Manitou dealer. Non-contractual document. Product descriptions may differ from actual products. List of specifications is not comprehensive. The logos and visual identity of the company are the property of Manitou and may not be used without authorisation. All rights reserved. The photos and diagrams contained in this brochure are provided for information only.

MANITOU BF SA - Limited company with board of directors - Share capital: 39,547,824 euros - 857 802 508 RCS Nantes